



Works Within Council Cemeteries Guidelines



Supporting Council’s Cemetery Strategy

Table of Contents

1.	Introduction	3
2.	Council Contacts.....	3
3.	Responsibility	4
4.	Licence to Work In Council Cemetery	4
5.	Operational Requirements for Works in Cemeteries	6
6.	Monumental Works	7
7.1.	Work Restrictions.....	9
7.2.	Requirement	9
7.3.	Worksite.....	9
7.4.	Clean Up.....	10
7.5.	Footings/Piers	10
7.6.	Monument Installation	10
8.	Incident and Accident Reporting.....	11
	Definition of Terms	12
	Attachment 1 – Table 2 - Minimum Pier Requirements	13
	Attachment 2 – Design Drawings for minimum width grave 1200mm	14
	Attachment 3 – Design Drawings for grave width less than 1200mm	15
	Attachment 4 – Design Drawings for headstone and base monument.....	16
	Attachment 5 – Design Drawings for monumental components	17

1. Introduction

Cessnock City Council has a responsibility to ensure that all activities conducted within its cemeteries comply with the requirements of the *Work Health & Safety Act 2011* associated legislative requirements and compliance with the relevant Australian Standards.

Cessnock City Council takes pride in the appearance and quality of its general and lawn Cemeteries and the following guidelines have been compiled to assist Council with managing external agents, sub-contractors and employees to ensure compliance and quality requirements are achieved.

These Guidelines apply to the following cemeteries under the care, control and management of Cessnock City Council and should be used in conjunction with Cessnock City Council Cemetery Procedures:

- Aberdare Cemetery, Greta Street, Aberdare
- The Gordon Williams Memorial Lawn Cemetery, Greta Street, Aberdare
- Branxton Cemetery, New England Hwy, Branxton
- Cessnock Cemetery, Wine Country Drive, Cessnock
- Ellalong Cemetery, Helena Street, Ellalong
- Glenmore Cemetery, Wine Country Drive, Lovedale
- Greta Cemetery, Evans Street, Greta
- Kurri Kurri Cemetery, Hospital Road, Weston
- Kurri Kurri Lawn Cemetery, Hospital Road, Weston
- Millfield Cemetery, Crump Street, Millfield
- Rothbury Cemetery, Wilderness Road, Rothbury
- Wollombi Cemetery, Maitland Road, Wollombi

2. Council Contacts

Cemetery Officer
02 4993 4220
cemetery@cessnock.nsw.gov.au

3. Responsibility

Council advises that all work is to be conducted between the hours of 6.30am and 4.00pm, weekdays unless otherwise approved in writing by Council.

Cessnock City Council is responsible for:

- Managing Council's cemeteries with safety and consideration
- These Guidelines
- The issue of work Licences subject to the applicant satisfying the requirements of these Guidelines and the licence application
- Auditing and assessing the activities of the applicant are conducted by random site inspection/audits
- Endorsing or voiding the Licence depending on the results of the assessment
- The maintenance of the site other than when an external agent is carrying out their activities.

External Agents (Agent) shall be responsible for:

- Monitoring activities on the site
- Making application for the Licence and providing sufficient conforming data to allow its issue
- Maintaining a management system capable of ensuring continuous maintenance of the Guidelines requirements
- Providing insurances, labour and equipment that conform to these requirements
- Informing the Council of their intention to enter and carry out activities on the site
- Managing the site and carrying out the work in compliance to this document and any Acts or Regulations pertaining to the works, particularly the *WHS Act 2011*, *WHS Regulation 2011*, Australian Standards and associated Codes of Practice
- Maintaining documented proof of compliance
- Report to Council any concerns that they have or find relative to either their own safety or the safety of others
- Abide and comply with Council's Smoke Free Workplace/Smoking Policy and Alcohol & Other Drugs Policy.

4. Licence to Work In Council Cemetery

Council requires all Agents who wish to work within Council's cemeteries to have a Licence.

The Licence:

- Authorises Agents to undertake works within a Cemetery. Where applicable, the Interment Right Holder or Agent engaged to undertake work on their behalf, must hold a specific Licence issued by Council to undertake that activity (such as Interment Right, Monumental Mason Licence, Exhumation Licence)
- May be reissued annually on application by the Agent and subject to audit by Council
- May be suspended or cancelled by Council for non-compliance to Council's requirements.

Documentation to be provided by Agents

	ASPECT	COUNCIL'S REQUIREMENTS <i>All required records are to be available for inspection by Council's Representative on request</i>	WHEN / WHERE REQUIRED
4.1 Personnel	Contractor, employees & subcontractors	Record of Construction General WHS Induction Record of training, tickets & certification for each appropriate to duties	Submitted with Licence application and available on request by any Council Employee during random audits
4.2 Insurance	Public Liability Insurance Minimum \$20,000,000	Certificate of Currency	Submitted with Licence application
	Motor vehicle/mobile plant insurance to \$20,000,000	Certificate of Currency Registered Vehicles	Submitted with Licence application
	Unregistered plant	Proof of cover either as part of motor vehicle or public liability cover. Note: Any damage arising as a result of the plant being used as a "tool of trade" is to be covered by either an extension of the Agent's Comprehensive Motor Vehicle Insurance or the liability endorsed onto the Agent's Public Liability Insurance.	Submitted with Licence application
4.3 Site	Site specific induction	Records of site inductions for each site for each employee/ subcontractor and when there is a change of activity or conditions Safe Work Method Statements Risk Assessments	Available on request on site during random audits

5. Operational Requirements for Works in Cemeteries

a. Engagement of Funeral Industry Staff

Council does not directly engage funeral industry staff to undertake work within its cemeteries. Typically:

- The Holder of an Interment Right engages funeral industry professionals as an Agent to undertake services and work on their behalf on Council land, then;
- The Agent provides services or undertakes work on Council land. The Agent, their employees and sub-contractors are subject to Council's requirements.

b. General Conditions for Interment

- Except as otherwise agreed to in writing by Council, interments may only take place at any interment site between 6.30am and 4.00pm weekdays with the exception of interments at lawn interment sites which are not permitted to take place after 2.30pm during the months of May, June, July and August
- The Agent shall notify Council of any activity proposed including times of commencement and completion
- Forty eight (48) hours' notice is required for a burial in any of Council's cemeteries. This requirement may be waived in special circumstances by application to Council
- Human remains may only be interred at any interment site with the written permission of Council, confirming the location of a reserved or existing site or the allocation of a new site
- All procedures involved with the burial process and transporting of human remains are in accordance with *Public Health Act 2010 and Public Health Regulations 2012* and the *WHS Act 2011* & associated legislation.

c. Burial Services

The Agent shall ensure that any persons attending a service at the interment site does not:

- Damage any part of the cemetery, including but not limited to any interment site or monument in the vicinity of the service
- Place any unauthorised tributes in a location not specifically approved in the subject burial right
- Bring to the cemetery any animal (other than a guide dog or companion animal on a lead)
- Park a vehicle on any known interment site, verge of plantation, or in a manner that is likely to impede traffic.

d. Grave Digging

The Agent shall ensure that all persons engaged to undertake grave digging:

- Implement effective safety measures as developed by the risk assessment. This may include the erection of barricades, protective restrains or reinforced covers to limit access to the site so as to ensure public safety and the installation of internal shoring of an approved type
- Excavate the plot shown on the map provided by Council
- Excavate graves within the specifications of 1.2m (w) x 2.4m (l)

- Dig graves to double depth – all new burial plots are sold as suitable for double depth unless specified otherwise
- Install external support of an approved type to ensure safety around grave site for every occurrence of activity
- Ensure suitable persons are available to assist funeral staff in maintaining safe conditions around the grave site
- Undertake manual handling of coffins or associated tasks in accordance with the *National Standard for Manual Tasks, 2007* and other relevant Standards
- Undertake any confined spaces work in compliance with *Work Health and Safety Act, 2011* and the *Australian Standard 2865-2009 - Confined Spaces*, and *WorkCover Confined Space Code of Practice*
- Have no less than two persons engaged or employed for the grave digging
- Have all ground support material, tools, equipment and personnel available at the site prior to the commencement of excavation
- Have been advised about the soil types at each cemetery to which the Policy applies, and that all excavation is carried out in line with the *WorkCover Excavation Work: Code of Practice* and the *Work Health and Safety Act, 2011*.

e. Completing an Interment

On completion of an interment the Agent shall ensure that:

- All planks, building equipment, protective coverings and soil are removed from adjoining interment sites or monuments, ensuring all such interment sites and monuments are cleaned thoroughly and washed if necessary
- The interment site, adjoining land, adjoining interment sites and monuments in the vicinity of the interment site are left in a neat and tidy condition
- All tributes relating to the interment are either removed from the cemetery or placed on the grave mound within the grave site
- Any excess soil is removed from the cemetery except where Council has approved an alternative
- Place a marker or cross bearing the deceased's name
- Ensure any dislocated slabs are replaced on the grave site within fourteen days of the completion of the interment.

6. Monumental Works

The following information has been compiled as a minimum standard for all Monumental works within Cessnock City Council Cemeteries.

All work is to be consistent with *Australian Standard AS 4204:2019* (Headstones & Cemetery Monuments). The Attachments and this information were developed from *AS 4204:2019* & experience drawn from the industry, which included discussion with Monumental Masons (Mason), Engineers and Local Government authorities.

To ensure compliance with the following requirements Council shall conduct random Site Audits. Works must be completed in accordance with schedule 1 as issued with approvals.

SCHEDULE 1

1. No work to commence without written approval by Cessnock City Council.
2. All work being carried out in accordance with Australian Standard, *AS 4204:2019* (Headstones and Cemetery Monuments), Section 7 of Cessnock City Council's Cemetery procedure and Work Health and Safety Management System.
3. The work shall be undertaken at any interment site between 6.30am and 4.00pm weekdays. If the Mason requires to work outside these hours they must seek prior written approval from Council's Recreation Services Manager.
4. At least 48 hours prior to commencement of the work the Mason shall advise Council via email to lyall.green@cessnock.nsw.gov.au or cemetery@cessnock.nsw.gov.au.
5. The Mason shall clean up and restore all disturbed areas prior to completion of the work at its cost and to the satisfaction of Council's Recreation Services Manager.
6. The Mason shall, when directed, promptly reinstate any damage to or disturbance of the existing monuments, interment sites or Council property. Council reserves the right to order removal of or remove offending, unauthorised or non-conforming work without notice.
7. Upon completion of the work the Mason shall request a final inspection for the work.

7.1. Work Restrictions

No person shall construct, erect, inscribe or remove any monument in a cemetery unless;

- An application to Council for the issue of a monument approval has been made on the appropriate form and accompanied by sketches, drawings, specifications and other particulars that clearly demonstrate the design of the proposed monument, and compliance with the *AS 4204:2019* and Council has issued a written monument approval
- The Mason only carries out work at the site and cemetery designated in the issued Monument Approval
- The Mason notifies Council of the date and time the works will be undertaken 48 hours prior to commencement of works
- A headstone is not to be installed before a period of three months following a burial
- Work is limited to that described in the approval and must be undertaken by qualified tradesmen in accordance with *AS 4204:2019* (Headstones & Cemetery Monuments) & the *WHS Act 2011*
- The Mason accepts responsibility for the immediate and effective repair of any damage to other monuments, interment sites or Council property while carrying out work in the Cemetery
- Does not park a vehicle on any known interment site, verge of plantation, or in a manner that is likely to impede traffic
- The monument is of a size and type approved by Council.

7.2. Requirement

- Council reserves the right to order removal of or remove offending, unauthorised or non-conforming work without notice
- Council will not be liable for the future care, maintenance, preservation, conservation or restoration of the construction, erected or placed over the grave.

7.3. Worksite

- It is the responsibility of the Mason and or subcontractor to ensure work site is kept safe, secure and clean at all times
- No open excavations are to be left unattended unless otherwise secured with barrier and/or boards to cover excavation
- Site is to be clearly defined to Cemetery visitors via means of bollards, safety cones or suitable devices
- No unauthorised persons are to enter worksite
- All reasonable care and compassion must be taken to ensure the safety, security, integrity and cleanliness of adjacent interment sites. Council accepts no responsibility for damage caused to adjacent burial plots whilst undertaking monumental works
- Council reserves the right to instruct repair and or restoration as a result of any subsequent damage.

7.4. Clean Up

- Work site must be left clean and tidy
- All building materials are to be removed from site at the end of job
- No building waste/rubbish is to be left under the ledger or slab
- Excess spoil must be removed from site
- Adjacent site disturbance must be reinstated and left level
- Adjacent interment plots must be clean.

7.5. Footings/Piers

- All footings are to be within the confines of the grave plot (1.2m(w) x 2.4m(l))
- No concrete paths/plinths/steps are to be poured at the front, side, behind or where grass pathways exist
- Where reasonably practicable installation of expansion joint material shall be installed between adjacent monuments
- Masons are to ensure all works are square and line up with existing structures or have sought Council assistance prior to construction
- Piers are to be drilled as per Attachment 1 AS 4204:2019 (Firm Clay) and a minimum four piers at 150mm diameter to depth of grave
- Contractors that are unable to obtain depth of pier are required to consult with Council prior to pouring footings.
- Footings for full monument installation are to be installed as per Attachment 1 AS 4204:2019 minimum footing requirements.
- Footing and Pier requirements for Single Headstone are to be installed as per Attachments 1 and 4 AS 4204:2019.
- Internal edge of footing adjacent to grave entry point must be formed up with suitable formwork timber
- All other formwork must be secure and in a safe condition
- Reinforcing steel as per Attachments 2, 3 and 4 AS 4204:2019 (preferably galvanised)
- Bar chairs are to be used to support steel to ensure minimum 50mm cover with concrete
- The minimum grade of concrete shall be N32 unless in a zone subject to seaspray in which case concrete shall be N40. Concrete that is mixed on site shall be mixed by measurement to ensure minimum strength is achieved. All concrete footings shall be vibrated in accordance with AS 3600
- Small footings < 0.2m³ may be mixed by hand
- Formwork to remain in place until concrete is dry for a minimum 24 hours.

7.6. Monument Installation

- No Structure shall be above 900mm above ground level
- All Monumental works must be within the designated plot
- All works are to be completed in accordance with Attachment 5 AS 4204:2019.
- All dowels are to be 340 Stainless as per AS 4204:2019
- Council shall conduct random audits on Masons

- No kneeling pads to front of monument permitted.
- Adhesives, bonding and fixing agents shall be appropriate to the application and used in accordance with manufacture's instructions.

8. Incident and Accident Reporting

The External Agent must:

- Be aware of all notifiable matters in accordance with the *WHS Act 2011* and the *WHS Regulation 2011*
- Immediately notify WorkCover and Council of any accident involving the death of or personal injury to any person
- Any dangerous occurrence as prescribed within Clause 341 of the NSW *WHS Regulation 2011* (whether or not injury is sustained) requiring the notification to WorkCover
- Immediately advise Council of any accident involving loss of time or incident with accident potential such as equipment failure, slides, cave-in and the like
- Immediately advise Council of any safety breaches/improvement notices/prohibition or infringement notices issued by the WorkCover Authority
- Immediately advise Council of any safety dispute between the Mason and its employees, agents or subcontractors
- If requested the Mason must provide a written report in the form directed by the Council. The Mason must, as soon as practicable after notification of any safety breach or hazard, take all measures necessary to remedy that breach or hazard

Definition of Terms

Council	Cessnock City Council
External Agent (Agent)	Funeral Directors, Monumental Masons, Contractors and their Employees and Subcontractors
Guidelines	The Guidelines for works within Council Cemeteries
Interment	<p>a) The placement of human remains in a mausoleum, vault, columbarium or other structure designed for the placement of such remains, or</p> <p>b) The burial in the earth of human remains (directly in the earth or in a container).</p>
Interment Right	Means an interment right granted under Part 4 of the <i>Cemeteries and Crematoria Act 2013</i> .
Interment Right Holder	Means the person recorded in the cemetery operator's register in relation to that cemetery as the holder of the interment right.
Interment Site	Means a place in a cemetery for the interment of human remains
Licence	A Licence issued by Council allowing an External Agent to undertake approved works in Cessnock City Council managed cemeteries
Principal	Cessnock City Council
WHS	Work Health and Safety

Attachment 1 – Table 2 - Minimum Pier Requirements

Foundation type	Description	Weight of monument — 3 to 4 tonnes		Weight of monument — 2 to 3 tonnes		Weight of monument — less than 2 tonnes	
		D mm	F mm	D mm	F mm	D mm	F mm
Sands, gravels	Medium sand or gravel	200	600	200	100	200	100
	Dense sand or gravel	150	300	150	100	150	100
Clays	Firm	150	600	150	300	150	300
	Stiff	150	400	150	200	No piers required	
	Very stiff to hard	150	150	No piers required		No piers required	
Rock	Highly to moderately weathered	150	100	No piers required		No piers required	

Attachment 2 – Design Drawings for minimum width grave 1200mm

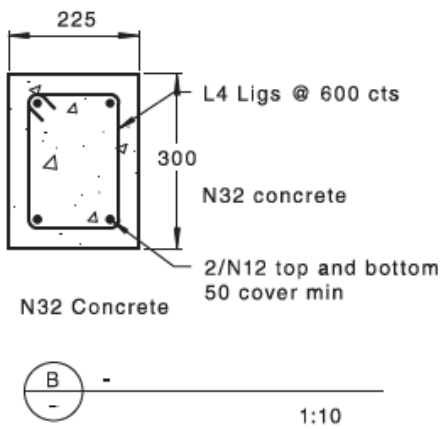
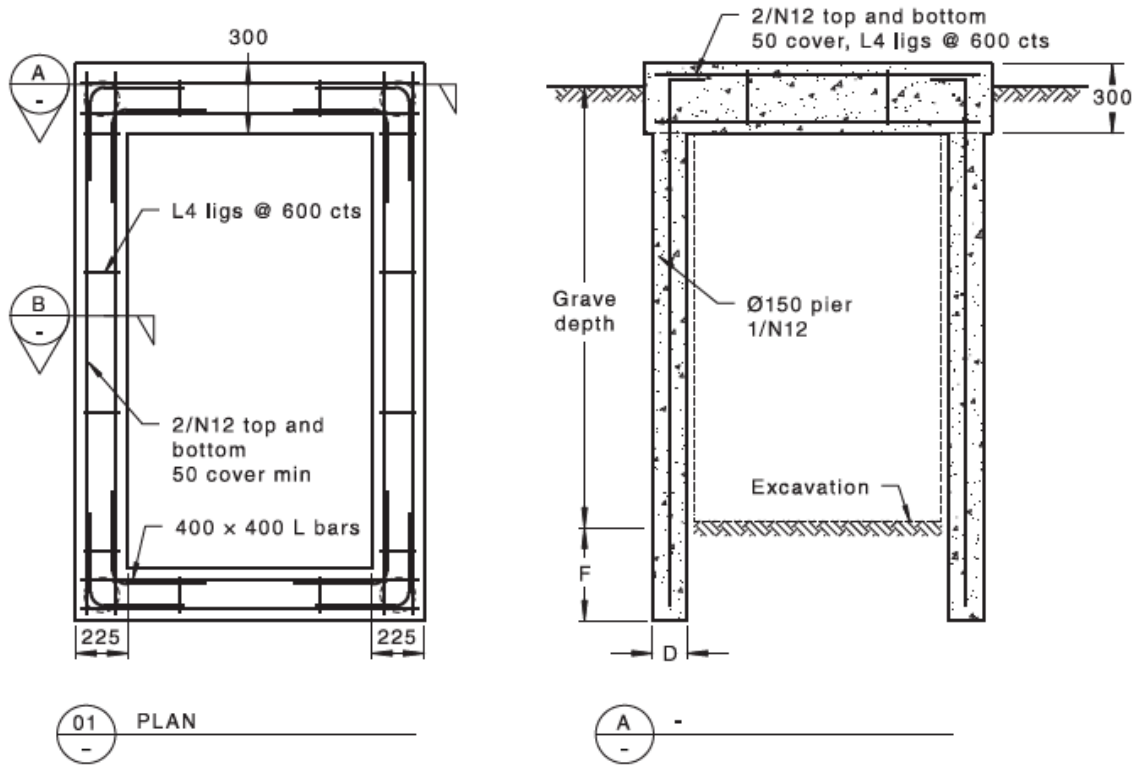

Attachment 3 – Design Drawings for grave width less than 1200mm

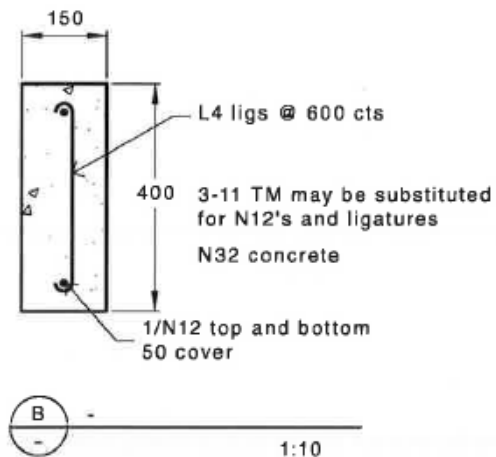
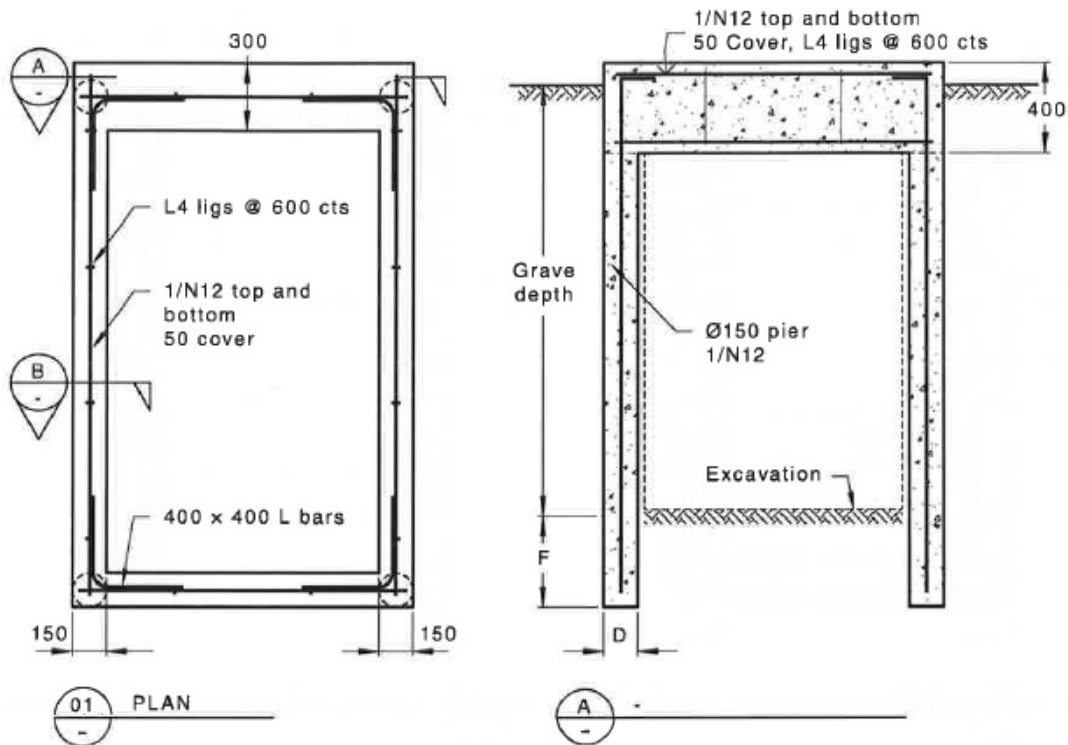

Attachment 4 – Design Drawings for headstone and base monument

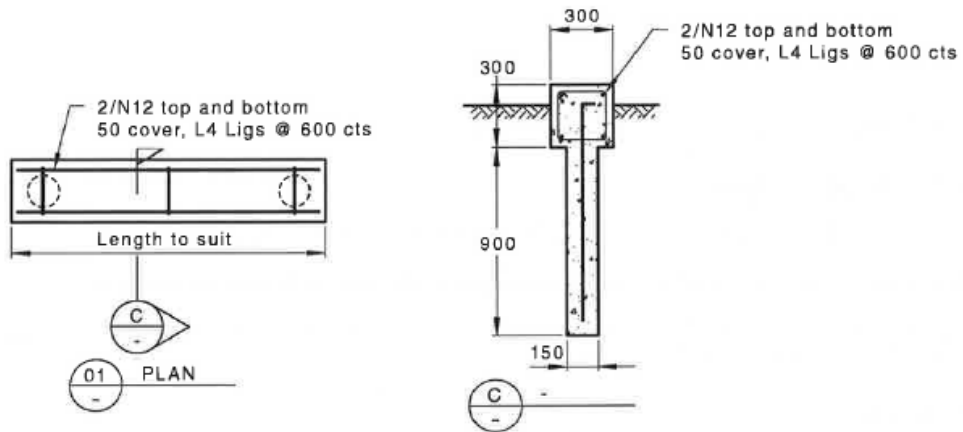

Attachment 5 – Design Drawings for monumental components

